

GRUNDFOS SRP RANGES

Recirculation pumps, Q up to 5,000 m³/h

LASTING **MOVEMENT**

Recirculation pumps for
high-flow, low-head applications

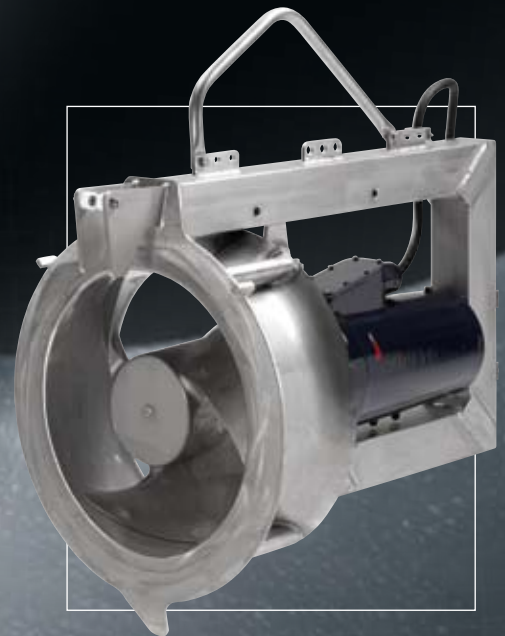

BE > THINK > INNOVATE >

GRUNDFOS 

RELIABLE RECIRCULATION

Submersible recirculation pumps 0.8 to 24 kW, four basic types

The Grundfos range of recirculation pumps is the final result of decades of engineering experience. Created to handle large flows against low head, the SRP models are equally suitable for wastewater treatment plants and flood control. Built for strength and reliability, the SRP will keep things moving – whether for steady process support or emergency relief.

SRP units come in three main variants – DN 300, 500, or 800 mm, respectively, fitted with motors from 0.8 to 24 kW. The units share many features with the AMG and AFG gear-driven mixers and flowmakers, making them instantly familiar to service staff and facilitating easy maintenance. All materials are selected for strength, and every component is thoroughly tested for durability before assembly. Recent evolutions include a triple sealing system for maximum protection of the

mechanical shaft seal as well as a very installation-friendly bracket.

SRP units often go into large and/or complex systems. When you design your system, we invite you to draw on the Grundfos fount of experience. Our application specialists can help you get the right flows by getting exactly the right pump. And you may well find that Grundfos' recommendations can save you substantial sums on construction. To make the most of our help, we urge you to call us at the earliest stage possible.

This leaflet serves as an introduction to the SRP. For full details on SRP models, sizing, accessories, etc., go online. Everything you need to know is there.

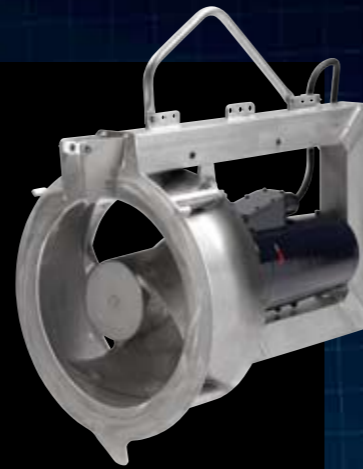

THE SRP AT WORK

For wastewater treatment or flood control

Being designed for recirculation, these specialised pumps will handle very large flows indeed – up to 5,000 m³/h. (Maximum head: 2.1 m). They are typically seen in wastewater treatment plants or waterworks, where they help maintain a steady flow in large-scale basins. But they are also used in industrial processes – and can play a crucial part in flood control setups thanks to their ability to shift large volumes of water quickly and reliably.

Typical application areas

- Wastewater treatment plants
- Water reservoirs
- Flood control
- Industrial process control

Installation

Easy installation was a priority in the evolution of the SRP range. The mounting bracket has been optimised on the basis of installer and customer input; for example, top/bottom fixation capabilities make the units instantly suitable for a very wide range of applications.

As a true Grundfos solution, the SRP can be integrated into your systems in more ways than one. The Grundfos CUE unit gives you access to simple and more advanced control features to match your demands; ask us for details.



SRP units create and maintain flows in treatment plants and industries worldwide.



When used for flood control, the SRP reliably protects land and settlements against encroaching water volumes.

SRP FEATURES

– and what they do for you

Watertight cable entry

A watertight cable entry point with self-shaping seal prevents cable damage.

Motor protection

The motor is protected against overload and overheating by three thermal switches or three thermistors placed in each motor winding.

Planetary gear

The gear housing has a slim design for optimal hydrodynamic properties.

Triple sealing system

The mechanical shaft seal is protected by an innovative triple sealing system for maximum reliability and durability. Find design details online.

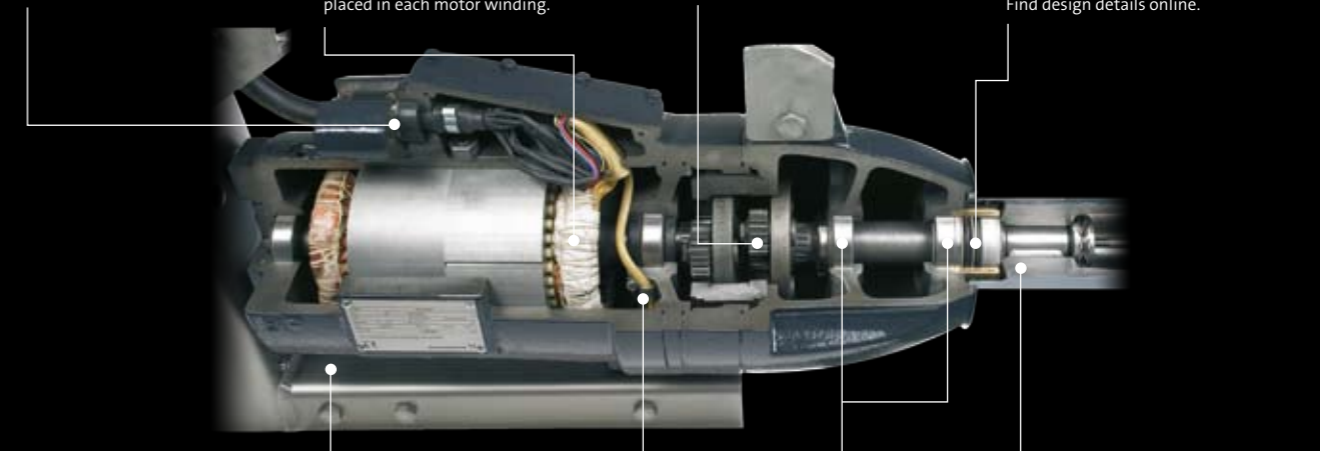

Innovative bracket design

Allowing for top or bottom fixation, this motor bracket is designed for easy installation in almost any setting and promotes stable operation.

Active electronic leak detector

Indicates possible liquid in the gear housing. Even the smallest quantity of liquid in the gear housing is quickly detected, allowing ample time for service before any damage is done.

Two tapered roller bearings

The gear shaft rests on two tapered roller bearings, which accommodate both axial and radial forces.

Choice of propellers

Hydrodynamic 2 or 3-blade propellers help ensure high efficiency and non-clogging operation. The propeller hub forms a labyrinth seal for the sealing system.

Performance overview

These performance curves should be seen as an indication of what the SRP range can do.

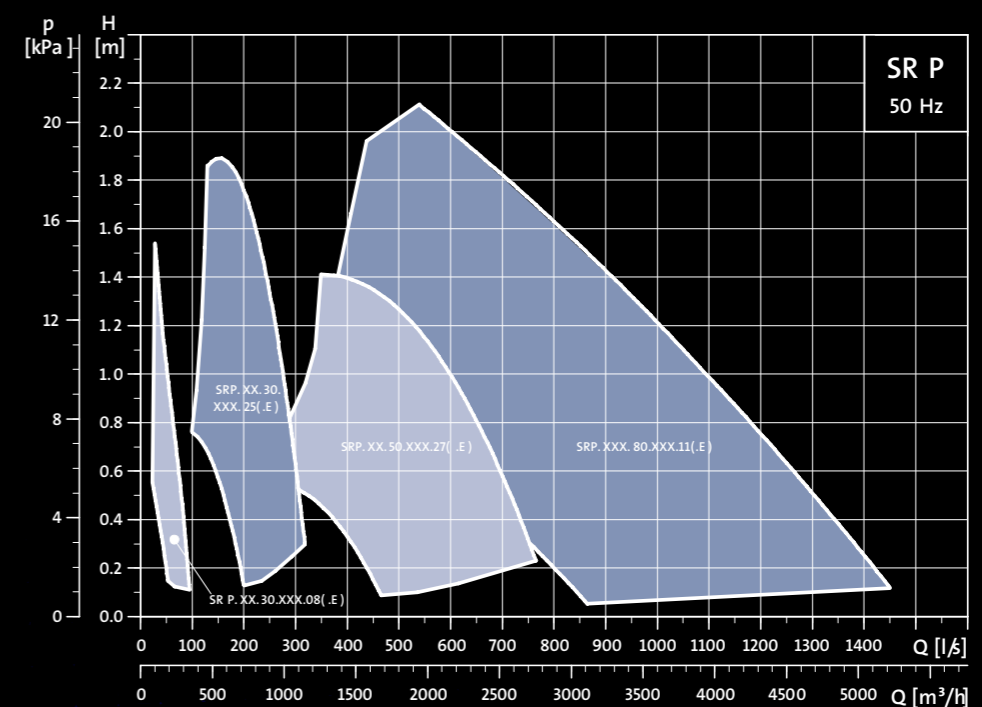

SEE THE BIGGER PICTURE

Grundfos is a global leader within water handling technology. Our passion is to bring you all the products you require to create and operate pump systems that combine reliability, cost-efficiency – and innovation. Our products are for use in water supply and wastewater infrastructure on any scale.

Grundfos has a full line of products and systems for the intake, treatment and distribution of drinking water and for the transport and treatment of wastewater. We also offer expertise and industry insight that can increase reliability and reduce lifecycle costs for water utilities.

Key product areas include:



Submersible pumps



Surface pumps



Sewage pumps



Mixers, flowmakers & recirculation pumps



Pumping stations



Monitoring & controls



Dosing & disinfection



Aeration equipment

Our products are the result of decades of engineering expertise. Supported by a worldwide service network. Visit water-utility.grundfos.com for more.

GRUNDFOS A/S

Poul Due Jensens Vej 7
DK-8850 Bjerringbro
Tel: +45 87 50 14 00

www.grundfos.com

The name Grundfos, the Grundfos logo, and the payoff Be–Think–Innovate are registered trademarks owned by Grundfos Management A/S or Grundfos A/S, Denmark. All rights reserved worldwide.