

Grundfos CRN Low NPSH

High temperature - poor inlet conditions

In industrial applications where pumps have to deal with the combination of high liquid temperatures and difficult inlet conditions or poor inlet pressure, the steady and reliable operation is often jeopardised by cavitation. Many years of collaboration with our customers in the industry, has taught us that it takes a special pump to deal with cavitation in industrial applications in order to avoid broken pumps and damaged systems.

Therefore, Grundfos has developed the CRN Low NPSH; a pump that is specially designed to eliminate the risk of cavitation and ensure a stable and reliable operation.



Advantages and the CRN Low NPSH

Stable operation

The CRN Low NPSH is a standard pump with an oversized inlet impeller and chamber that improve the pump's suction capabilities. This construction prevents erosion from occurring and destruction of pump parts such as the impeller, piping system or valves from taking place. Additionally, the pump does not produce as much noise as a traditional CR does. Despite the fact that the CRN Low NPSH is subject to higher amount of stress than traditional pumps because of its improved inlet design, it ensures a stable operation.

Compact system design

Because of the CRN Low NPSH, it is possible to design a more compact system; that is a system that does not take up too much room. The CRN NPSH reduces the excess pressure itself,



and do not require any additional tank to provide supplementary pressure. In boiler feed applications, where many big tanks are gathered, a compact system is an advantage.

Longer lifespan

By eliminating the risk of cavitation, the CRN Low NPSH provides a more stable flow for a longer period of time. The pump is no longer subject to the damage that cavitation causes on different pump parts, and is ensured a considerable longer lifespan than a traditional pump.

Technical data	
Max. pressure	25 bar
Max. ambient temp.	40°C
Max. liquid temp.	120°C
Min. inlet pressure	No change from standard CR/CRN
Min. flow	No change from standard CR/CRN

Custom-built solutions

The comprehensive standard Grundfos CR programme covers a wide range of pumps, for a wide range of different industrial applications. Besides, Grundfos designs custom-built pump solutions; acknowledging that sometimes it does not take more, than a little extra effort, to come up with the right solution. With a custom-built pump solution from Grundfos, your pump is capable of handling even higher pressures, more aggressive liquids, excessive liquid temperatures etc.

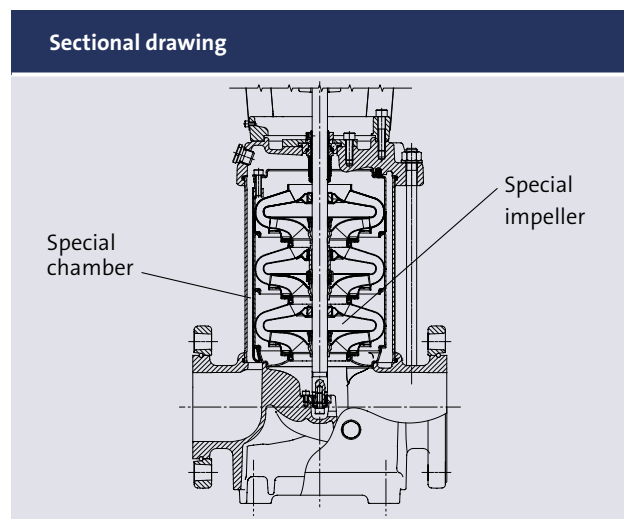

Worldwide pump supplier

Being a worldwide pump supplier, Grundfos has committed itself to provide its clients with a global, reliable and efficient service network. Our experienced team of service technicians are always ready to serve you wherever in the world you are and – of course – at a short notice – whenever you need it.