

GRUNDFOS AMG, AMD, and AFG RANGES

Mixers and flowmakers, 0.75 - 18.5 kW

60 Hz DIN

KEEP YOUR PROCESSES **MOVING**

Mixers and flowmakers for wastewater and
sludge applications

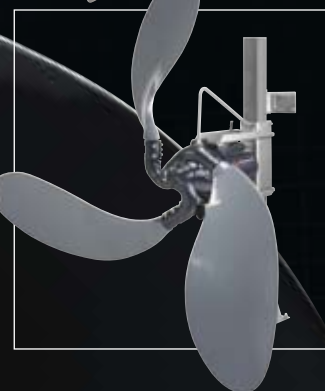

STIRRING SUPPORT FOR YOUR SYSTEMS

Mixers and flowmakers. Creating flows on any scale.

Grundfos is dedicated to making wastewater systems of any kind as reliable and efficient as possible. Our AMD, AMG, and AFG ranges reflect this dedication. Very dependable and highly efficient, these submersible mixers and flowmakers prevent sedimentation and support processes in treatment plants, industries, and agriculture.

All models share many features, facilitating easy maintenance. Materials are selected for strength, and every component is tested for durability before assembly. Recent evolutions include a triple sealing system for maximum protection of the mechanical shaft seal as well as an installation-friendly bracket.

Grundfos mixers are available with direct (AMD) or planetary gear-driven (AMG) stainless steel or polyamide propellers. All flowmakers (AFG) are gear-driven and share the AMG motor design.

- AMD (direct-driven) mixers are available in 8-pole versions in range from 1,5-4,5kW
- AMG (gear-driven) mixers are available from 1.5-18.5 kW.
- AFG flowmakers are available from 1.3-7.5 kW.

When you design your systems, we invite you to draw on the Grundfos fount of experience. Our application specialists can help ensure the right flow characteristics, velocities, etc. You may well find that Grundfos' recommendations can save you substantial sums on construction. To make the most of our help, we urge you to call us at the earliest stage possible.

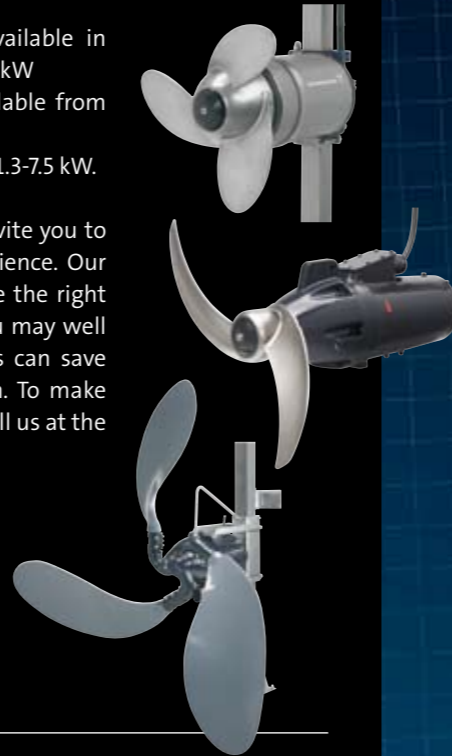

THE AMD, AMG, AND AFG AT WORK

Mixers and flowmakers make sure that particles remain evenly distributed in wastewater and sludge, preventing sedimentation and supporting treatment processes.

A complete range of installation accessories is available for all models. For full details, visit Grundfos WebCAPS online.

The range covers everything from small-scale mixers, ideal for prefabricated pumping stations, to large-scale flowmakers created for large tanks and basins. Wastewater infrastructure is an obvious application area – from network stations to treatment plants – but the mixing power of the AMD, AMG, and AFG ranges is also appreciated by industries and agricultural professionals worldwide.

Typical application areas

- Sewage pumping stations
- Wastewater treatment plants
- Industrial processes
- Agriculture

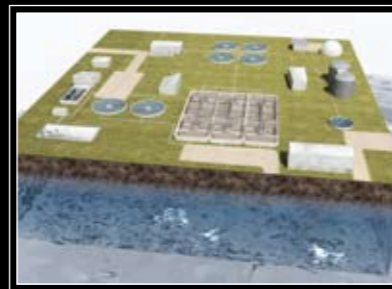

Mixers are ideal for preventing sedimentation in small-scale pumping stations.

Installation

Great care has been taken to ensure easy installation of the Grundfos mixer/flowmaker ranges. The mounting bracket has been optimised on the basis of installer and customer input; for example, top/bottom fixation capabilities make the units instantly suitable for a very wide range of applications.

Different control options are available to match your system – from start/stop to more sophisticated functions. Ask us for more.



Flowmakers can create the flow and velocities you require. For best results, ask us for design assistance.

MIXER AND FLOWMAKER FEATURES

– and what they do for you

AMD

Innovative bracket design
Bracket design optimized for easy installation – adaptable for many different applications with no need for customisation.

Motor housing
Stainless steel AISI 316; smooth, self-cleaning surface.

Protection ring
POM protection ring prevents fibres from snagging on the propeller shaft.

Self-cleaning propeller
Hydrodynamic 3-blade propeller and hub with excellent self-cleaning capabilities, made from stainless steel AISI 316.

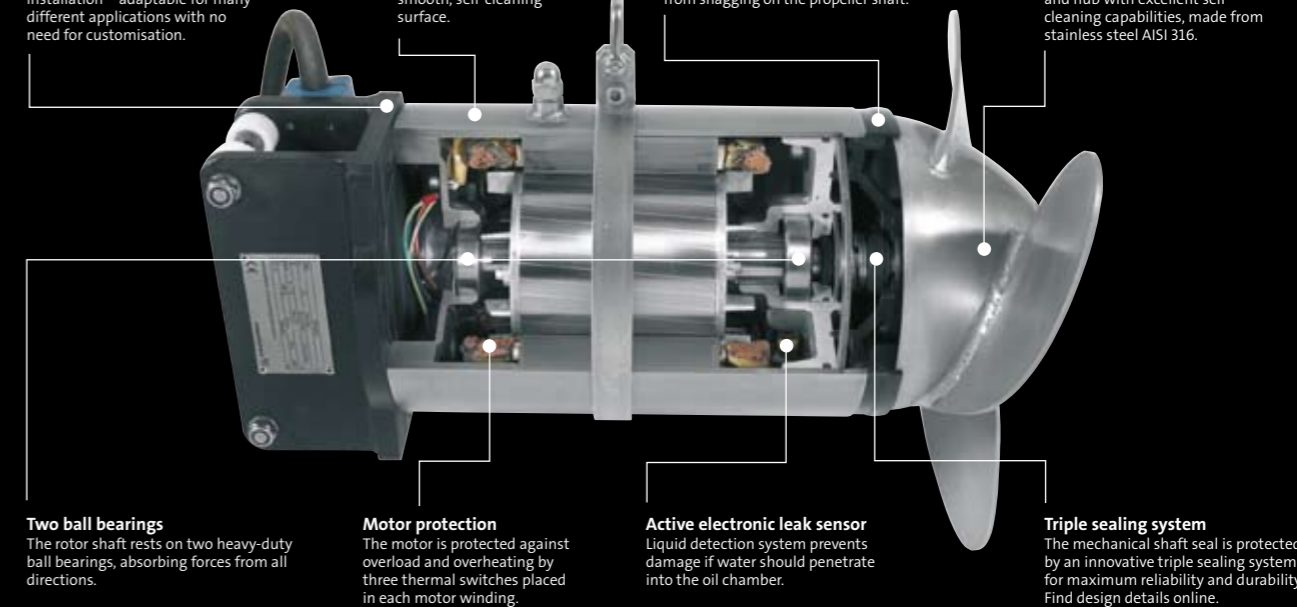

Two ball bearings
The rotor shaft rests on two heavy-duty ball bearings, absorbing forces from all directions.

Motor protection
The motor is protected against overload and overheating by three thermal switches placed in each motor winding.

Active electronic leak sensor
Liquid detection system prevents damage if water should penetrate into the oil chamber.

Triple sealing system
The mechanical shaft seal is protected by an innovative triple sealing system for maximum reliability and durability. Find design details online.

AMG/AFG

Watertight cable entry
A watertight cable entry point with self-shaping seal prevents cable damage.

Motor protection
The motor is protected against overload and overheating by three thermal switches or three thermistors placed in each motor winding.

Planetary gear
The gear housing has a slim design for optimal hydro-dynamic properties.

Triple sealing system
An ingenious triple seal system protects the mechanical shaft seal, minimising wear and service requirements.

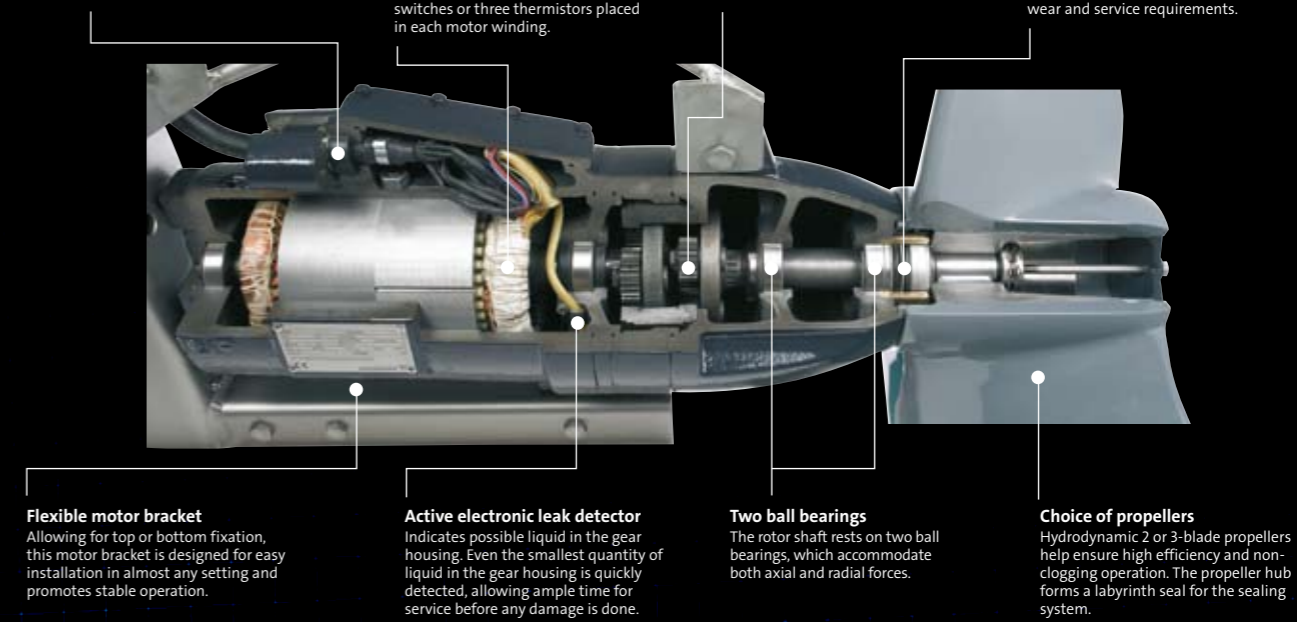

Flexible motor bracket
Allowing for top or bottom fixation, this motor bracket is designed for easy installation in almost any setting and promotes stable operation.

Active electronic leak detector
Indicates possible liquid in the gear housing. Even the smallest quantity of liquid in the gear housing is quickly detected, allowing ample time for service before any damage is done.

Two ball bearings
The rotor shaft rests on two ball bearings, which accommodate both axial and radial forces.

Choice of propellers
Hydrodynamic 2 or 3-blade propellers help ensure high efficiency and non-clogging operation. The propeller hub forms a labyrinth seal for the sealing system.

SEE THE BIGGER PICTURE

Grundfos is a global leader within water handling technology. Our passion is to bring you all the products you require to create and operate pump systems that combine reliability, cost-efficiency – and innovation. Our products are for use in water supply and wastewater infrastructure on any scale.

Grundfos has a full line of products and systems for the intake, treatment and distribution of drinking water and for the transport and treatment of wastewater. We also offer expertise and industry insight that can increase reliability and reduce lifecycle costs for water utilities.

Key product areas include:

-  Submersible pumps
-  Surface pumps
-  Sewage pumps
-  Mixers, flowmakers & recirculation pumps
-  Pumping stations
-  Monitoring & controls
-  Dosing & disinfection
-  Aeration equipment

Our products are the result of decades of engineering expertise. Supported by a worldwide service network. Visit www.grundfos.com/water-utility for more.